



2R-III



# Leach 2R-III Rear Loader

THE STRONG. THE PROUD.

Day after day, Leach™ rear loaders stand unwavering, built robustly to take on even the most challenging routes. Leach™ takes immense pride in the outstanding quality and productivity of each unit.

Every option, every design refinement, and every feature that Leach™ incorporates into its units share a common objective: optimizing fleet efficiency while minimizing maintenance costs. Each Leach™ rear loader is crafted to offer the finest product on the market with the lowest total cost of ownership.

Proven time and time again, the 2R-III rear loader can handle a broad spectrum of materials, from everyday refuse to heavy-duty construction waste. Whether for residential, commercial, or demolition collection, the 2R-III stands as the most versatile rear loader available.

## Laying the foundations for a truly exceptional product.

### LEACH™ INNOVATIONS

With a strong emphasis on innovation, Leach's engineering team has crafted a comprehensive range of customizable options to cater to even the most stringent customer requirements. We are poised and eager to embrace emerging industry trends and fulfill evolving customer demands. This perpetual cycle of innovation positions Leach™ as the forefront leader in rear loader solutions across North America.

### WEIGHT DISTRIBUTION

Over years of innovation, Leach™ trucks prioritize ideal weight distribution in all models. Our ongoing objective is to achieve the perfect material balance, ensuring models collect more waste while maintaining the highest legal payload.



**ENVIROLINK™ HAS LAID THE FOUNDATIONS FOR A BRAND-NEW ERA IN TRUCK INTELLIGENCE.**

An improved electrical network and analog system, cameras, lights and monitors, safety interlocks, alerts, GPS tracking, and more are now packaged in a more precise, reliable, and efficient Smart Collection Package



Enclosed reeving cylinder for commercial applications

Diamond Force compaction design

21 yd³ to 32 yd³ body sizes

Ejector cylinder angled upward away from debris

Interchangeable packer cylinders

Available AR Steel liners in the hopper

Low load sill height of 4-5/8" below frame

Up to 1000 lbs/yd³ compaction

	AUTOMATED	MANUAL	RESIDENTIAL	COMMERCIAL	DEMOLITION	ORGANICS	ALLEYS TIGHT AREAS	RECYCLING	TIPTO DUMP	FULL EJECT	SPLIT BODY	50>82 DGE	50>96 DGE	50>100 DGE	60>97 DGE	FRAME	ROOF	CAB	TAILGATE	EV
<b>LEACH</b> 2R-III		●	●	●	●			●		●				◆ CNG		◆ CNG	◆ CNG	◆ CNG		●

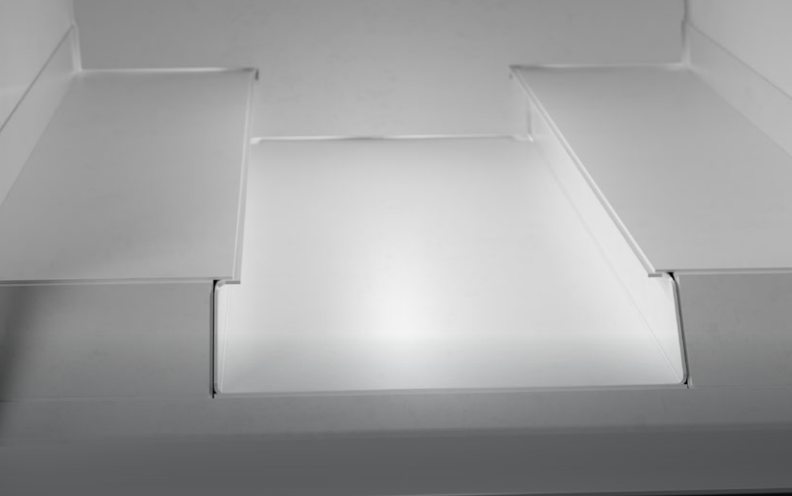

### **THICKEST BODY FLOOR**

At 5/16" in the center and 1/4" on each side, Leach™ units boast the thickest standard floor in the industry.



### **LARGEST HOPPER SWEEP**

The industry's largest hopper sweep, with 5.5" and 4.5" hydraulic cylinders, maximizes waste capacity, reduces packer cycles, and increases payload efficiency.



### **LEACH™ TROUGH**

Spanning the full body length, the distinctive Leach™ trough design forms a built-in sump capable of holding up to 300 gallons of liquid. It also enhances stability with a lower center of gravity and improved weight distribution.



### **LOADING SILL**

a low tailgate loading sill increases productivity and reduces operator injuries.



### **CHROMIUM SLIDE SHOES**

Slide shoes with chromium carbide components operate in upper and lower rails, ensuring superior durability over AR450. Greaseable pins and accessible lubrication points facilitate easy maintenance for extended service life.

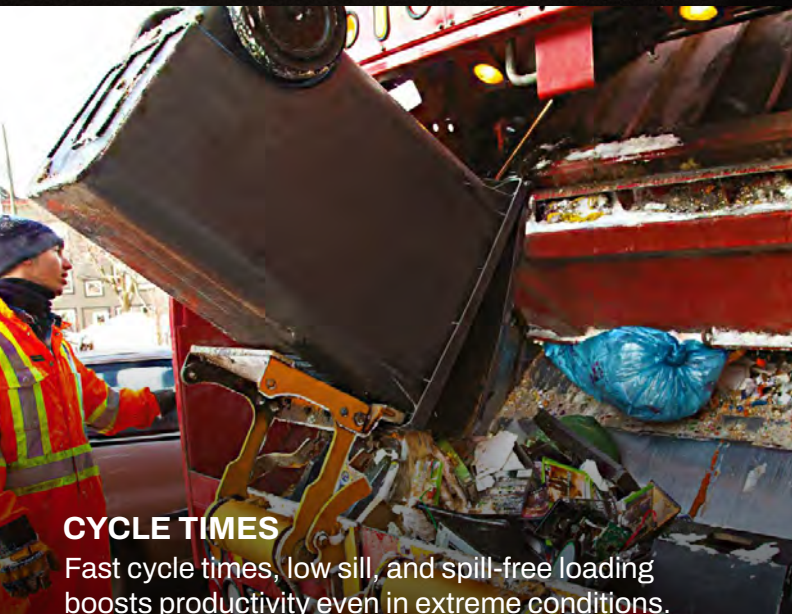

### **CYCLE TIMES**

Fast cycle times, low sill, and spill-free loading boosts productivity even in extreme conditions.

\*Compaction ratios will vary based on commodity and environmental factors

## 2R-III Specifications

Body Specs	2R-III HD Residential	2R-III HD Demolition	2R-III HD Commercial
Body Trough Floor	5/16" 50W 50,000psi	5/16" 50W 50,000psi	5/16" 50W 50,000psi
Body Sides	10ga A1011 80,000psi	10ga A1011 80,000psi	10ga A1011 80,000psi
Body Roof	10ga A1011 80,000psi	10ga A1011 80,000psi	10ga A1011 80,000psi
Body Ramp Liners	-	1/4" A715 GR80 80,000psi (AR 450, 175,000 psi optional)	1/4" A715 GR80 80,000psi (AR 450, 175,000 psi optional)
Body Roof Liner (Body Rear End)	-	-	10ga A1011 80,000psi
Body Sides Liners (Body Rear End)	-	-	10ga A1011 80,000psi

Hopper Specs	2R-III HD Residential	2R-III HD Demolition	2R-III HD Commercial
Hopper Size (yd <sup>3</sup> )	3.5	3.5	3.5
Hopper Opening Width	80"	80"	80"
Hopper Opening Height	57.5"	57.5"	57.5"
Hopper Depth	18-1/4"	18-1/4"	18-1/4"
Loading Sill Below Chassis Frame	4-5/8"	4-5/8"	4-5/8"
Hopper Floor	1/4" 100QT 100,000psi (AR 450, 175,000 psi optional)	1/2" 100QT 100,000psi (AR 450, 175,000 psi optional)	1/2" 100QT 100,000psi, front liner 1/4" A514 100,000psi
Hopper Sides (upper)	1/4" 50W 50,000psi (AR 450, 175,000 psi optional)	1/4" 50W 50,000psi (AR 450, 175,000 psi optional)	1/4" 50W 50,000psi
Hopper Sides (lower)	1/4" 50W 50,000psi (AR 450, 175,000 psi optional)	1/4" 50W 50,000psi (AR 450, 175,000 psi optional)	1/2" 50W 50,000psi

Body Dimensions	21yd <sup>3</sup>	25yd <sup>3</sup>	29yd <sup>3</sup>	32yd <sup>3</sup>
A. Overall Length, Tailgate Closed (in.)	263	285	318	341
Overall Width (in.)	102	102	102	102
B. Overall Height Above Frame, Tailgate Closed (in.)	93	93	93	93
C. Overall Length, Tailgate Open (in.)	279	301	334	357
D. Overall Height Above Frame, Tailgate Open (in.)	184	184	184	184

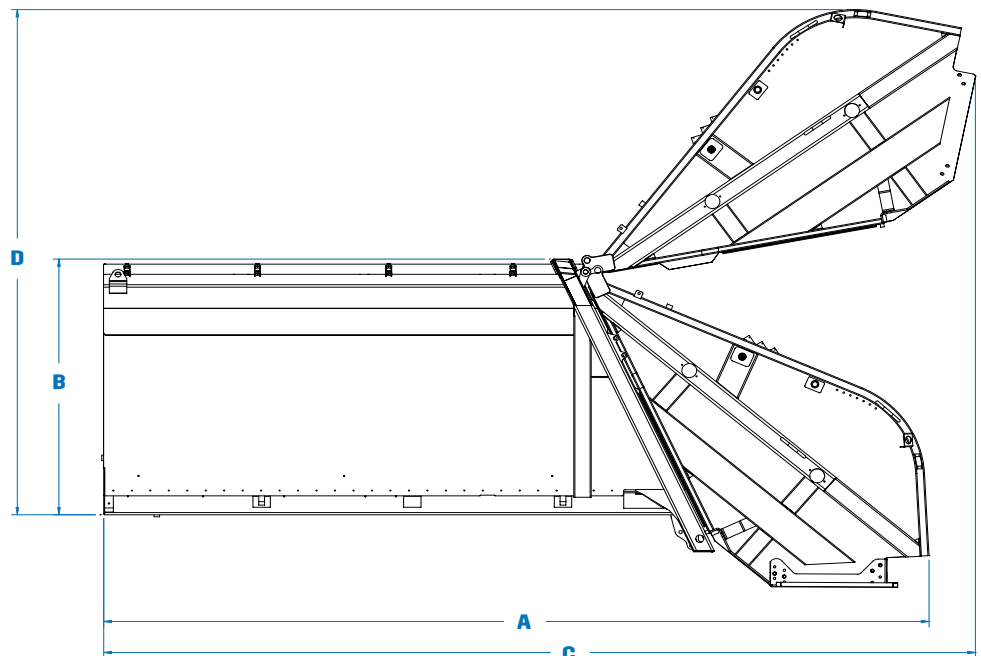
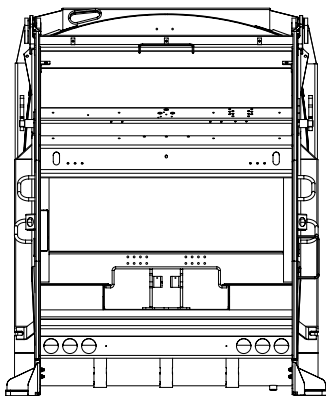

Cylinder Specs	2R-III HD Residential	2R-III HD Demolition	2R-III HD Commercial
Ejector Cylinder (20yd <sup>3</sup> bodies)	3 stages 6-1/2" bore x 94-1/4" stroke	3 stages 6-1/2" bore x 94-1/4" stroke	-
Ejector Cylinder (25yd <sup>3</sup> bodies)	3 stages 6-1/2" bore x 115-9/16" stroke	3 stages 6-1/2" bore x 115-9/16" stroke	3 stages 6-1/2" bore x 115-9/16" stroke
Ejector Cylinder (29yd <sup>3</sup> bodies)	4 stages 6-1/2" bore x 148-1/4" stroke	4 stages 6-1/2" bore x 148-1/4" stroke	4 stages 6-1/2" bore x 148-1/4" stroke
Ejector Cylinder (32yd <sup>3</sup> bodies)	5 stages 7-1/2" bore x 147-7/8" stroke	5 stages 7-1/2" bore x 147-7/8" stroke	5 stages 7-1/2" bore x 147-7/8" stroke
Packer Cylinders	5-1/2" bore x 4-1/2" rod x 30-5/16" stroke	5-1/2" bore x 4-1/2" rod x 30-5/16" stroke	5-1/2" bore x 4-1/2" rod x 30-5/16" stroke
Carrier Cylinders	5-1/2" bore x 4-1/2" rod x 30-5/16" stroke	5-1/2" bore x 4-1/2" rod x 30-5/16" stroke	5-1/2" bore x 4-1/2" rod x 30-5/16" stroke
Tailgate Cylinders	4" bore x 3-1/2" rod x 32-11/16" stroke	4" bore x 3-1/2" rod x 32-11/16" stroke	4" bore x 3-1/2" rod x 32-11/16" stroke

Hydraulic Specs	2R-III HD Residential	2R-III HD Demolition	2R-III HD Commercial
Pump	Gear	Gear	Gear
Pump Capacity	42 gpm @ 1200 rpm	42 gpm @ 1200 rpm	42 gpm @ 1200 rpm
Max. Operating Pressure	2,300 psi	2,300 psi	2,300 psi
Oil Reservoir	50 gal	50 gal	50 gal

Ejector Specs	2R-III HD Residential	2R-III HD Demolition	2R-III HD Commercial
Ejector Panel Face Plate	3/16" 50W 50,000psi	3/16" 50W 50,000psi	3/16" 50W 50,000psi

Packer-Carrier Specs	2R-III HD Residential	2R-III HD Demolition	2R-III HD Commercial
Compaction ratio (lbs/yd <sup>3</sup> )	1000	1000	1000
Packer Panel Face Plate	1/4" A656 100QT	1/4" 100QT	1/4" 100QT liner 1/4" 50W 50,000psi
Carrier Panel Face Plate	3/16" 50W 50,000psi	3/16" 50W 50,000psi	3/16" 50W 50,000psi, liner 3/16" 50W 50,000psi

Performance Specs	2R-III Heavy Duty Residential	2R-III Heavy Duty Demolition	2R-III Heavy Duty Commercial
Packer/Carrier Cycle Time	23-26 sec	23-26 sec	23-26 sec
Tailgate Open	10 sec @ 700 rpm	10 sec @ 700 rpm	10 sec @ 700 rpm
Tailgate Close (with Safety Flow limiter)	30 sec @ 700 rpm	30 sec @ 700 rpm	30 sec @ 700 rpm

Note: Specifications subject to change without notice

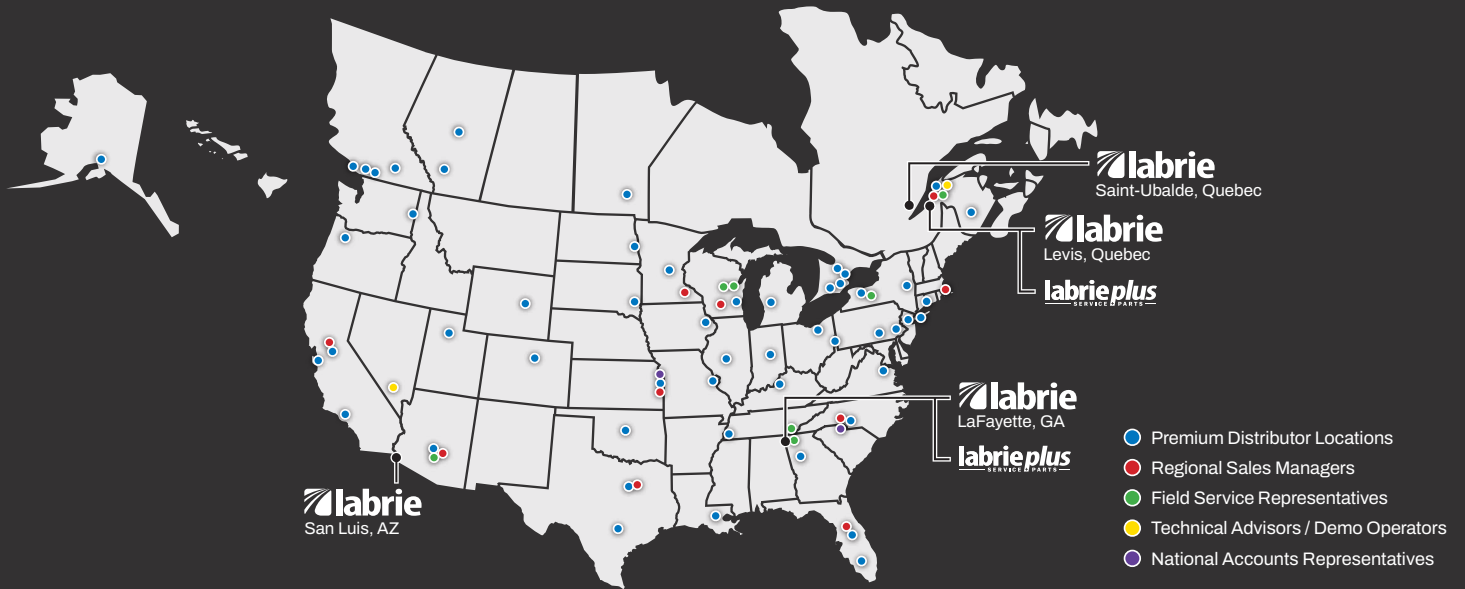

## Our North American network is dedicated to quality.

Leach™ trucks are supported by over 30 top-tier distributors spanning across 50+ sites in the US and Canada, guaranteeing a commitment to driving excellence and providing expert support.



Opt for the Leach™ Pronto Stock Program when a pre-built model makes sense. Benefit from expedited delivery, cost savings, and a wide selection of models designed to cater to even the most demanding collection needs.



With Sourcewell, save time and money by combining the buying power of more than 50,000 government, education, and nonprofit organizations.



# DRIVE EXCELLENCE™



175-B, route Marie-Victorin, Lévis, Quebec, Canada, G7A 2T3  
 Toll Free: 1-800-463-6638 | Telephone: 418-831-8250  
 sales@labriegrup.com | www.labriegrup.com



**United States of America**  
 1198 Shattuck Industrial Blvd, Lafayette, GA, 30728  
 Toll Free: 1-800-231-2771  
 usa.labrieplus.com | partscenter@labrieplus.com

**Canada**  
 455 Ave 1, Levis, Quebec, Canada, G6W 5M6  
 Toll Free: 1-877-452-2743  
 canada.labrieplus.com | labriepluqc@labriegrup.com